

Scale 1:3

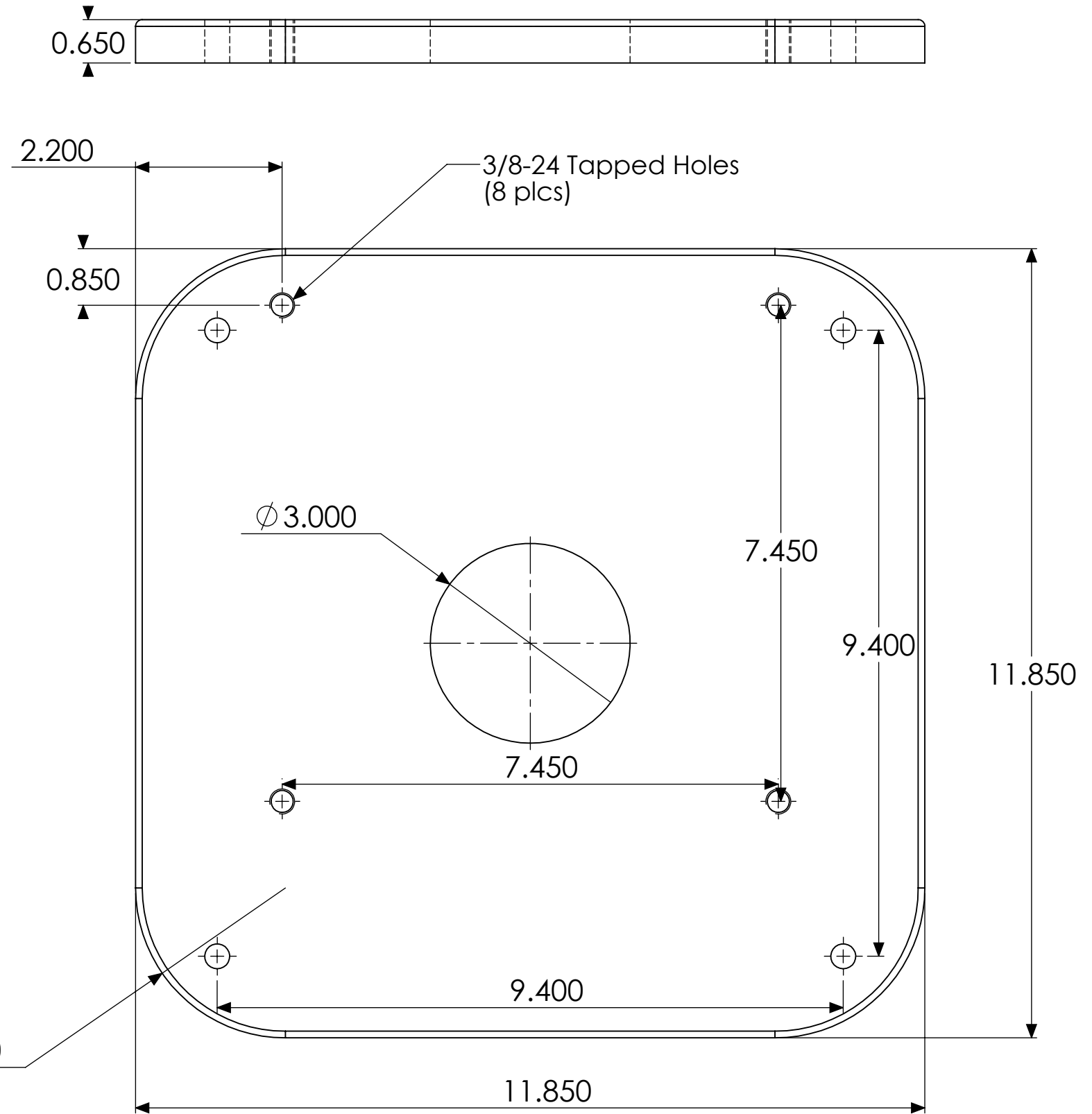

**PROPRIETARY AND CONFIDENTIAL**  
 THE INFORMATION CONTAINED IN THIS DRAWING IS THE SOLE PROPERTY OF SOFTWARE BISQUE. ANY REPRODUCTION IN PART OR AS A WHOLE WITHOUT THE WRITTEN PERMISSION OF SOFTWARE BISQUE IS PROHIBITED.

Stock Size  
 Fixturing  
 Assembly  
 Number

DIMENSIONS ARE IN INCHES  
 TOLERANCES:  
 FRACTIONAL ±  
 TWO PLACE DECIMAL ± 0.020  
 THREE PLACE DECIMAL ± 0.005  
 MATERIAL  
 FINISH  
 DO NOT SCALE DRAWING

	INITIALS	DATE
DRAWN		
CHECKED		
ENG APPR.		
MFG APPR.		
Q.A.		

COMMENTS:

Software Bisque

Project: **Paramount MX**

Part Name:  
**mx permanent pier top plate**

SIZE **A** DWG. NO.

Rev **1**

SCALE: 1:2 WEIGHT:

SHEET 1 OF 1